

附逆止閥行控型迴轉油壓缸

ROTATING HYDRAULIC CYLINDER WITH STROKE CONTROL AND SAFETY DEVICE

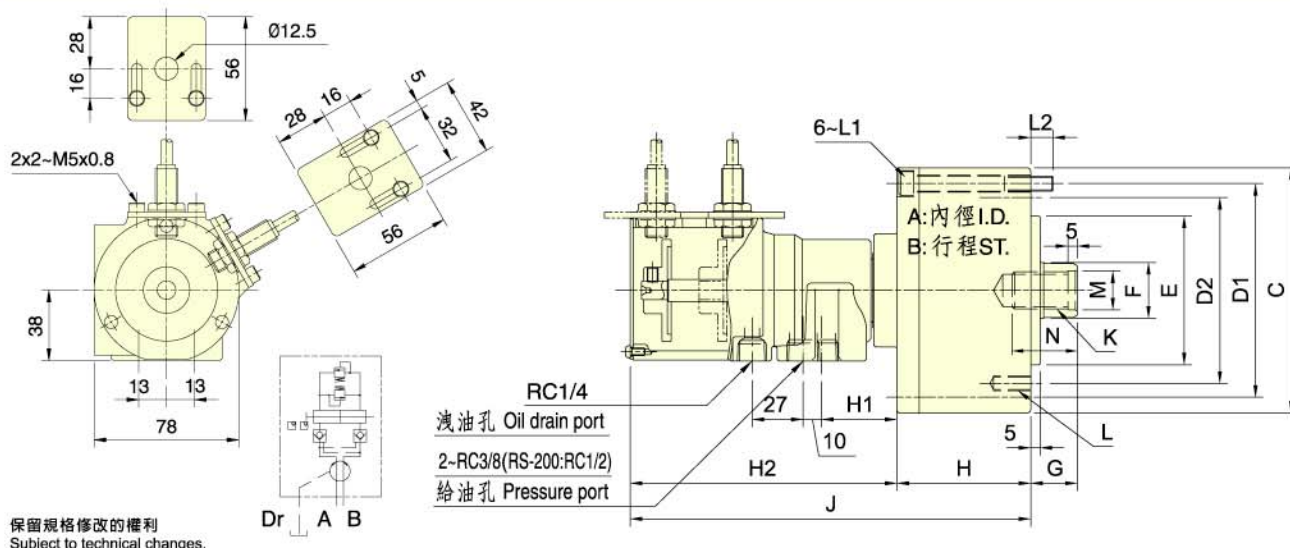

- 短型，高速，行程控制型迴轉油壓缸。
- 感應式近接開關，行程調整容易，可確認油壓缸正確作動。
- 內建逆止閥自鎖機構及壓力洩壓閥。
- 安裝時可由後端鎖固之。
- For short form, high speed and stroke control.
- To ensure safe power chuck operations by conforming movement of the piston in the cylinder.
- Built-in safety check valves and pressure relief valves.
- Can screw it from the rear end of the cylinder when mounting.
- 洩油孔配管務必單獨接回油壓槽，以避免產生背壓。
- The drain port should be independently connected to oil tank to avoid back pressure.



近接開關型式：

Proximity sensor : Model TLX-12N02E1-C(KFPS) DC 12-24V 200mA NPN

規格 Spec.	活塞面積 Eff. piston area cm ²		行程 mm	最高迴轉數 min ⁻¹ (r.p.m)	最高使用壓力 MPa	I kg·m ²	重量 kg
型號 Model	伸側 Extend	拉側 Retract	Piston stroke	Max. speed	Max. pressure (kgf/cm ²)	Moment of inertia	Weight
RS-75	43.0	37.1	15	6000	4.0 (40)	0.01	3.4
RS-100	77.4	71.5	20			0.04	4.9
RS-125	121.6	113.1	25			0.05	7.4
RS-150	175.6	160.8	30	5500	4.0 (40)	0.10	10.7
RS-200	313.0	290.4	35			0.29	15.9

寸法 Size 型號 Model	A	B	C	D1	D2	E h7	F	G		H	H1	H2	J	K	L	L1	L2	M H8	N
								max.	min.										
RS-75	75	15	107	90		65	30	45	30	57	42	145	202	M20x2.5	6~M8x16	M8x60	12	21	35
RS-100	100	20	132	115	100	80				72									
RS-125	125	25	160	140	130	110	35	50	25	82	41	144	226	M24x3.0	6~M12x20	M8x85	16	32	45
RS-150	150	30	190	170			45	55	95	39	142	237	M30x3.5	12~M12x24	M10x100				
RS-200	200	35	245	220	145	120	55	70	35	115	36	142.5	257.5	M36x4.0	12~M16x30	M10x125	21	38	60